



RatioMatic Burners

Model RM300

Version 3.10

Main Specifications - RM300

PARAMETER		SPECIFICATIONS			
		English		Metric	
		Capacity @ Chamber Pressure			
		BTU/hr	@ "w.c.	kW	@ mbar
Maximum input	60 Hz packaged blower	3,550,000	-5.0	1040	-12,4
		3,220,000	-2.0	940	-5,0
		3,000,000	0.0	880	0,0
		2,740,000	2.0	800	5,0
	50 Hz packaged blower	2,300,000	5.0	670	12,4
		3,500,000	-5.0	1020	-12,4
		3,170,000	-2.0	920	-5,0
		2,950,000	0.0	860	0,0
Note: Contact factory for varying chamber pressures or pressures outside the range: -5.0 to 5.0" w.c. (-12,4 to 12,4 mbar)		2,690,000	2.0	780	5,0
		2,250,000	5.0	650	12,4
Minimum input		BTU/hr		kW	
		65,000		19	
Main gas inlet pressure • fuel pressure at ratio regulator inlet		"w.c.		mbar	
Natural gas		20 to 55		50 to 140	
Propane or Butane		20 to 35		50 to 90	
High fire flame length • measured from the outlet end of the combustor		inches		mm	
Natural gas		60 in		1500 mm	
Propane or Butane		65 in		1650 mm	
Maximum chamber temperature		°F		°C	
Alloy tube		1500		815	
Block & Holder		1900		1040	
Flame detection		Alloy tube		Flame rod or UV scanner	
Block & Holder				UV scanner only	
Fuel		Natural Gas, Propane or Butane. For any other mixed gas, contact Eclipse Combustion for orifice sizing			

- All information is based on laboratory testing. Different chamber size and conditions will affect the data.
- Maximum inputs are given for the standard combustion air blower without an air filter.
- All inputs based upon gross calorific values and standard conditions; 1 atmosphere, 70° F (21°C).
- Eclipse reserves the right to change the construction and/or configuration of our products at any time without being obliged to adjust earlier supplies accordingly.

Performance Graphs
RatioMatic RM300

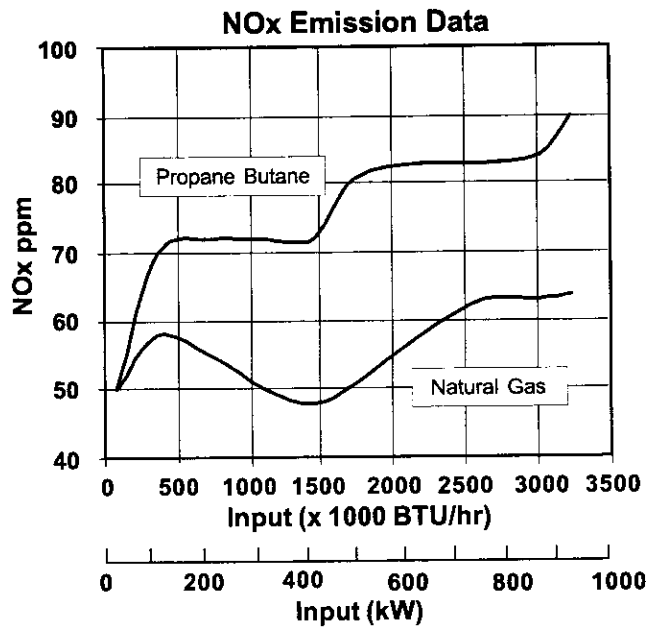
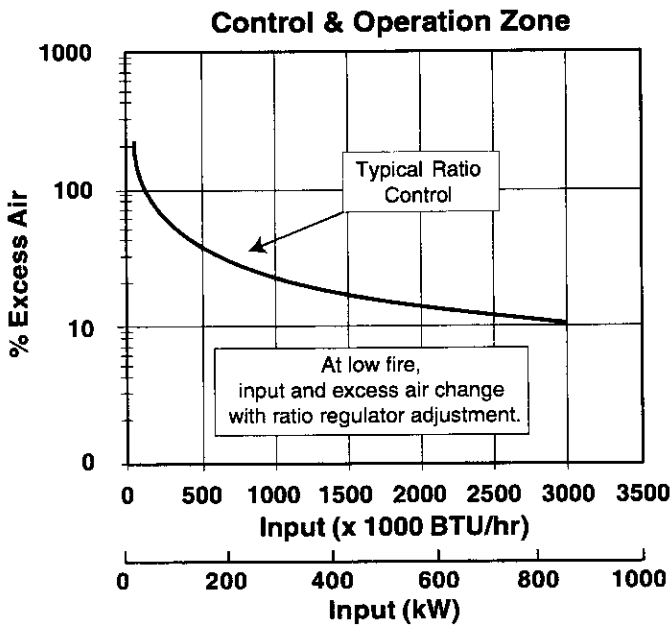

Notes on emission data	
<p>NOx emission data is given for:</p> <ul style="list-style-type: none"> • Ambient combustion air ~70° F (20° C) • Less than 1000°F (540°C) firing chamber • Minimal process air velocity • Low fire input adjusted to 65,000 BTU/hr (19kW) • ppm volume dry at 3% O₂ • Neutral chamber pressure 	<p>Emissions are influenced by:</p> <ul style="list-style-type: none"> • Chamber conditions • Fuel type • Firing rate • Ratio regulator adjustment • Combustion air temperature
<p align="center">CO emission is largely influenced by chamber conditions. Contact your local Eclipse Combustion representative for an estimate of CO emission on your application.</p>	

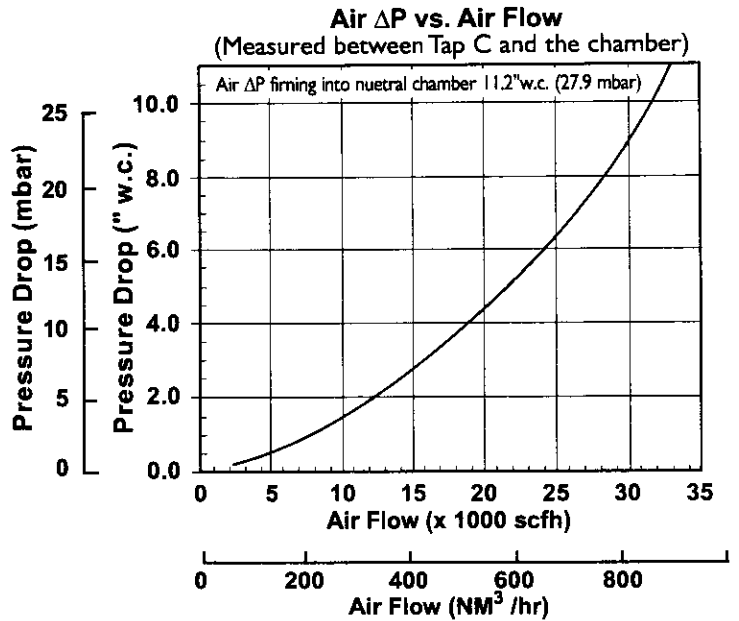
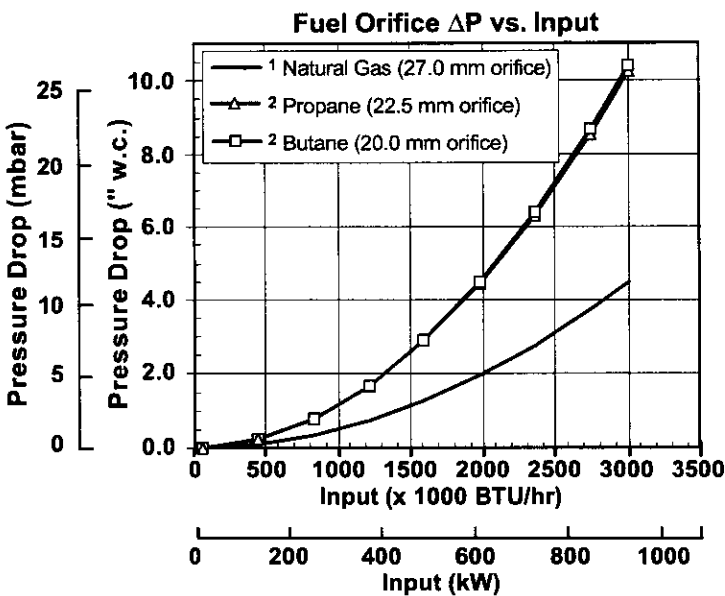

¹Natural Gas ΔP measured between Taps B and D

²Propane and Butane ΔP measured between Tap B and the chamber

Dimensions-RM300

Dimensions mm (in)

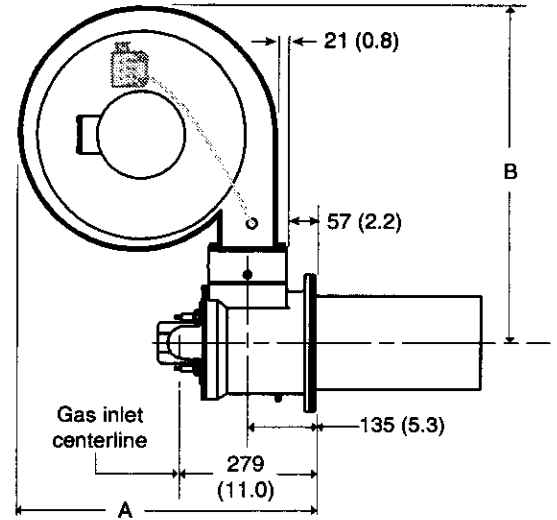
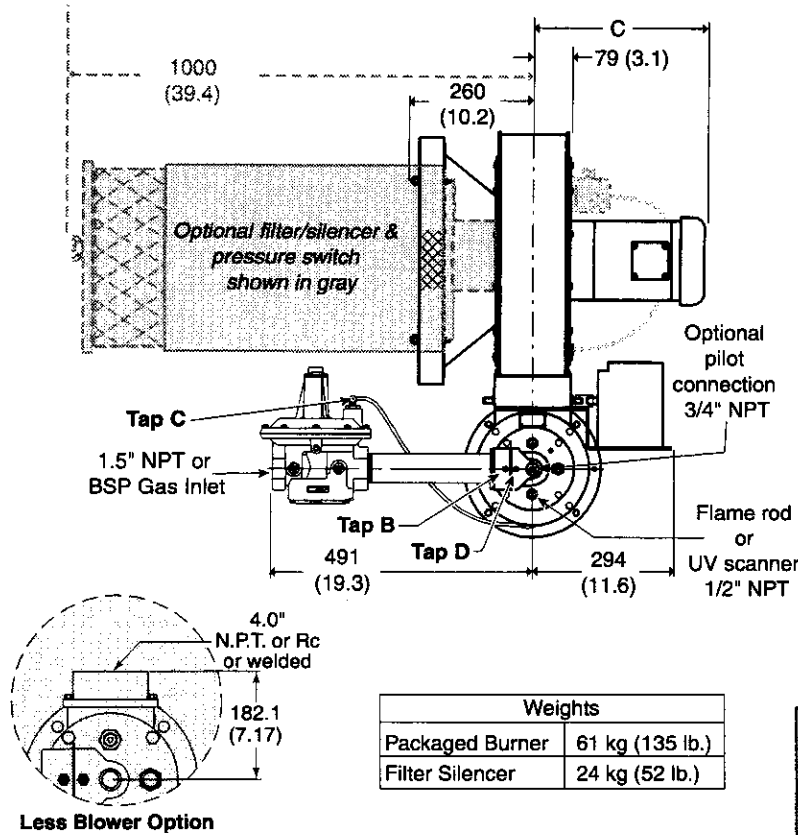

Weights	
Packaged Burner	61 kg (135 lb.)
Filter Silencer	24 kg (52 lb.)

	A	B	C
50 Hz	614 (24.2)	704 (27.7)	350 (13.8)
60 Hz	555 (21.8)	650 (25.6)	332 (13.1)
60 Hz (Auto)	555 (21.8)	650 (25.6)	383 (15.1)

Note: See Price List 110 for available spare parts.

Combustor types

Alloy tube

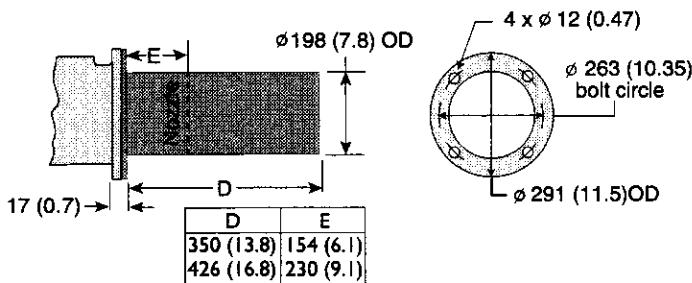

Block & Holder

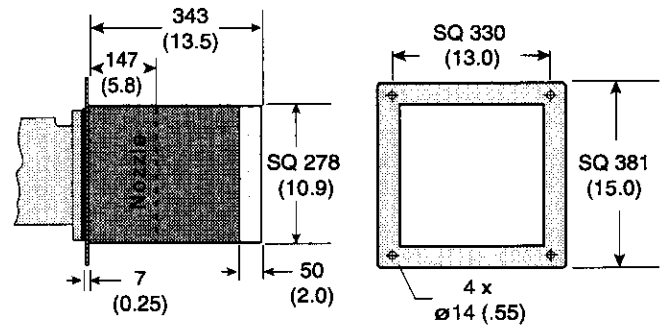

Burner configuration

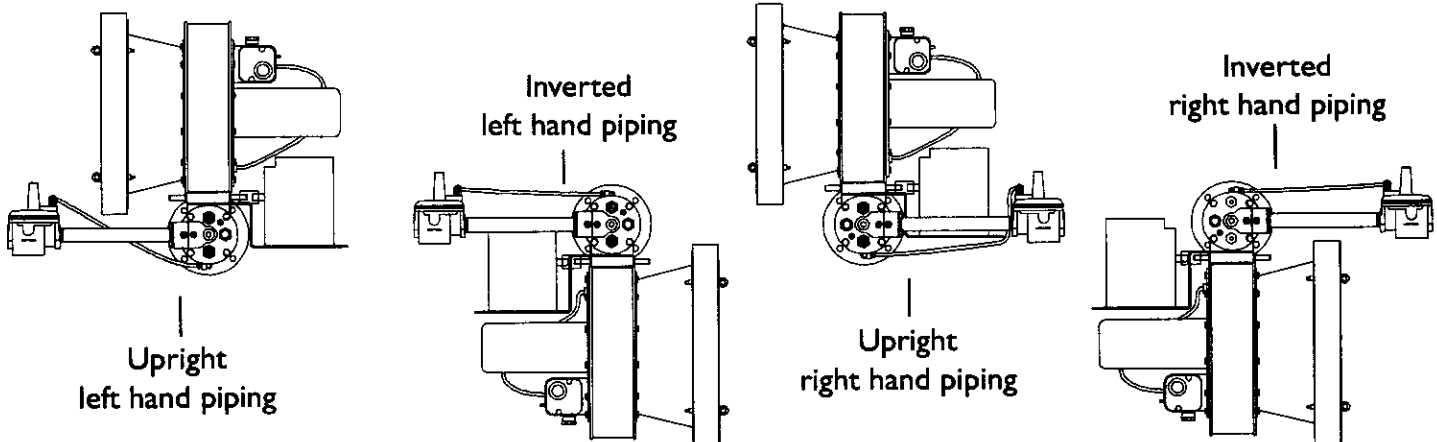



Offered By:

Power Equipment Company
2011 Williamsburg Road
Richmond, Virginia 23231
Phone (804) 236-3800
Fax (804) 236-3882

www.peconet.com